

EQ5 Motor Drive

Dual Axis

1.

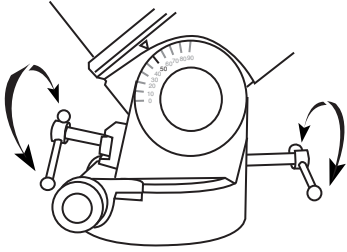

2.

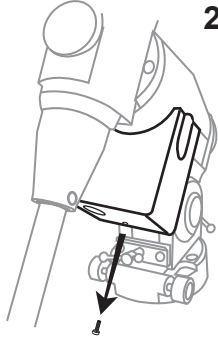

3.

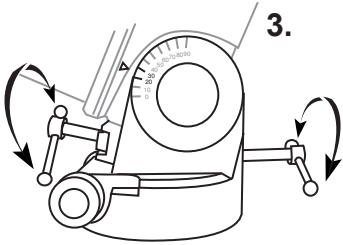

4.

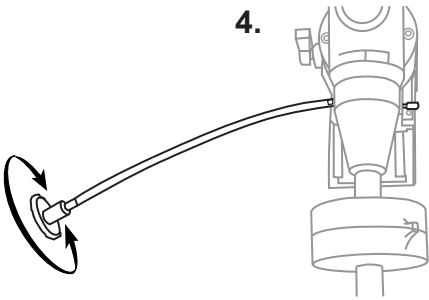

Before beginning the installation process, remove the telescope tube from the mount for ease of installation.

R.A. MOTOR INSTALLATION

- 1) Turn the altitude adjustment knob until the latitude scale indicates 50°.
- 2) Locate plastic box underneath R.A. axis. Unscrew small phillips screw at bottom to remove box.
- 3) Turn the altitude adjustment knob until the latitude scale indicates 25°.
- 4) Rotate R.A. fine-adjustment cable until the flat surface of nipple faces forward.
- 5) Slide shaft gear onto end of R.A. axis worm gear. Tighten set screw to hold shaft gear in place using the 2mm hex key provided.
- 6) Place motor drive into recess. Orient motor so that threaded hole in motor drive mounting plate aligns with the elongated hole near the top of the recess. Ensure gear on motor meshes with the shaft gear assembly.
- 7) Attach 4mm key hex onto long screw and thread through hole and screw into backside of motor mounting plate. Fasten screw to secure motor to equatorial mount.

5.

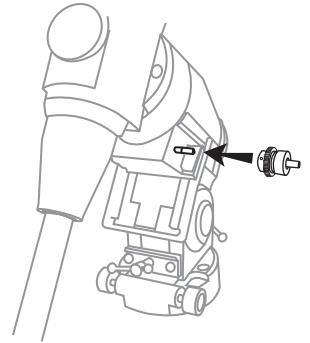

6.

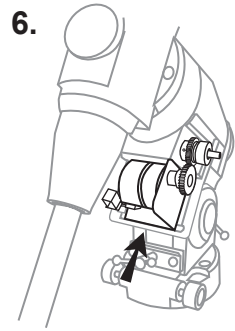

7.

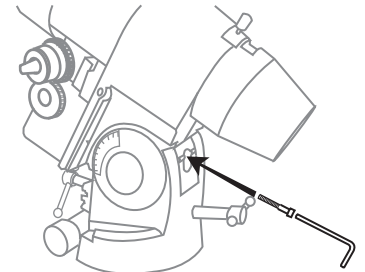

DEC MOTOR INSTALLATION

- 8) Loosen set screw on gear assembly. Slide shaft gear assembly over end of DEC worm gear. Tighten set screw against flat surface of worm gear nipple.
- 9) Locate DEC motor. Use the 5mm hex screw provided to fasten motor to the underside of the mounting bracket. Orient motor so that gear faces backwards and meshes with shaft gear assembly as seen in Fig. 9-1.

8.

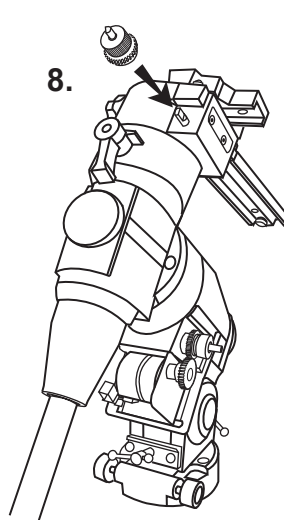

9.

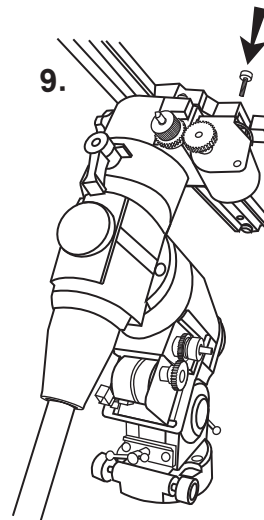

9-1.

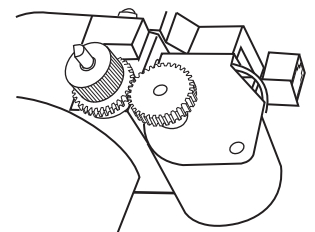

DEC MOTOR INSTALLATION (continued)

- 10) Turn the altitude adjustment knob until the latitude scale indicates 50°.
- 11) Replace plastic cover and secure with small phillips screw.
Remove oval tab from side cover to allow space for the shaft gear assembly.
- 12) Plug R.A. and DEC cords from control box into appropriate RJ-11 jacks on electric motors.
- 13) Plug DC power cord from battery case into control box.

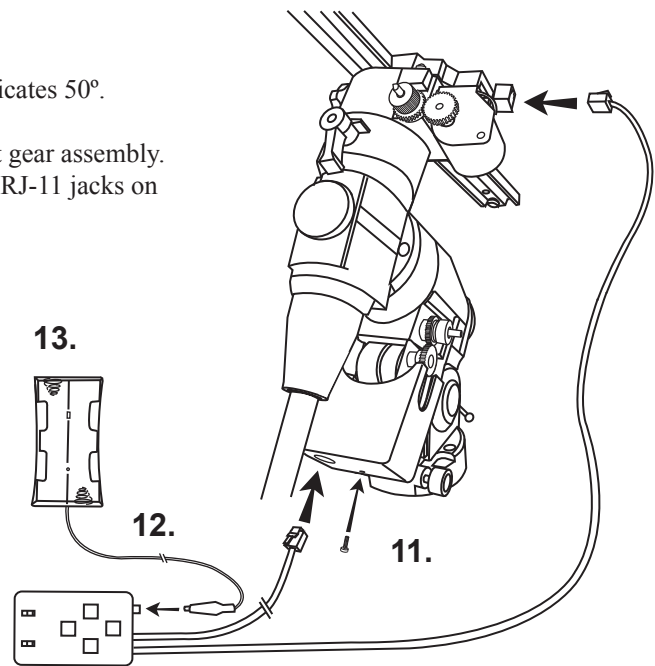
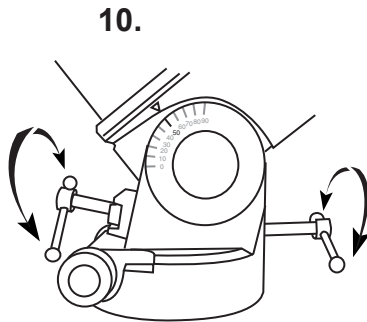

OPERATION

When control box is turned on and all buttons are depressed, the R.A. motor will rotate at the proper speed to compensate for the earth's rotation. The declination axis does not automatically rotate. For proper polar-aligned observing, no corrections are needed to the declination axis to track celestial objects. The speed of the declination motor is simultaneously controlled by the 2X/4X/8X control box switch.

The shaft gear assembly operates as a friction clutch to allow disengagement of the motor drive. To use the declination fine-adjust cable, loosen the knurled wheel on the shaft gear to disengage motor. Tighten wheel to engage motor again. The declination axis locking knob can be loosened for slewing without having to disengage motor gear first. When the power is on and all buttons on the control box are depressed,

The N/Off/S switch acts as a power switch as well controlling direction of clock drive. The "N" position allows R.A. motor to track for Northern Hemisphere observing and the "S" position is suitable for the Southern Hemisphere. The 2X/4X/8X switch changes rotation speed used by the control box buttons. It sets rotation rate for multiple of tracking speed. The up-down buttons control the declination motor while the left-right buttons change the R.A. axis.

The right "2X" button will rotate the telescope forward at twice the tracking speed or approximately $\frac{1}{2}^\circ$ per minute. The left "2X" button stops all motion and allows stars to drift by at their normal rotation rate of approx. $\frac{1}{4}^\circ$ per minute. The "8X" buttons allows forward at eight times the tracking rate (approx. 2° per minute) and the reverse button move the telescope backwards at seven times the tracking rate (approx. $1\frac{3}{4}^\circ$ per minute).

The tracking speed of the R.A. motor is factory set and should not need adjustment. Adjustment of the variable resistor inside the control box should be performed by an experienced technician

It may be necessary to loosen the worm gear for the R.A. or declination axis to allow a the motor drive to rotate freely. The interface for the worm gear is located inside the rectangular section which the fine-adjust cables are attached. The worm gears are held in place by two pairs of 5mm hex screws located behind and below the rectangular section. The bottom two hex screws will have a 2mm set screw between them. Carefully loosen all four screws a small amount. Loosen the 2mm set screw about $\frac{1}{4}$ turn. Re-tighten the four hex screws holding the worm gear in place. If the worm gear assembly is too loose, excess backlash will be detected in the motor gears. It will be necessary to tighten the worm gear set screw about a $\frac{1}{4}$ turn.

Technical Support

Canada: 604-270-2813 between 9:00AM and 3:00PM PST
Outside Canada: Please contact your dealer for technical support.