

B-290 Series

INSTRUCTION MANUAL

Model
B-290 series (B-292 / B-292PLI / B-293 / B-293PLI)
B-290LD series (B-292LD1.50 / B-292LD1 / B-293LD1.50 / B-293LD1)
B-290TB series (B-290TB)

Ver. 6.1 2026



Table of contents

1.	Warning	3
2.	Safety Information	3
3.	Package content	4
3.1	B-292/B-292PLI/B-293/B-293PL	4
3.2	B-292LD1.50/B-292LD1/B-293LD1.50/B-293LD1	5
3.3	B-290TB	6
4.	Unpacking	7
5.	Intended use	7
6.	Symbols and conventions	7
7.	Instrument description	8
7.1	B-292/B-292PLI/B-293/B-293PL	8
7.2	B-292LD1.50/B-292LD1/B-293LD1.50/B-293LD1	9
7.3	B-290TB	10
8.	Assembling	11
8.1	Assembling the microscope	11
8.1.1	B-292/B-292PLI/B-293/B-293PLI	11
8.1.2	B-292LD1/B-292LD1.50/B-293LD1/B-2932LD1.50	12
8.1.3	B-290TB	13
8.2	Polarizing set (optional)	15
9.	Use of the microscope	16
9.1	Switching on the microscope	16
9.2	Light intensity adjustment	16
9.3	Coarse focus tension adjustment	16
9.4	Stage	16
9.5	Adjust the interpupillary distance	17
9.6	Diopter adjustment	17
9.7	Use of oil immersion objective	17
9.8	Condenser centering	18
9.9	Aperture diaphragm	18
9.10	Use of fluorescence	19
9.11	Use of the polarizer (optional)	19
9.12	Phase Contrast observation (optional)	20
9.12.1	Brightfield observation (BF)	20
9.12.2	Phase Contrast observation (PH)	20
10.	Microphotography	22
10.1	Cameras with projection lens	22
10.2	Reflex camera	22
11.	Use of software and digital head	23
12.	Micrometric Slide M-005	23
13.	Maintenance	24
14.	Troubleshooting	25
	Equipment disposal	26

1. Warning

This microscope is a scientific precision instrument designed to last for many years with a minimum of maintenance. It is built to high optical and mechanical standards and to withstand daily use. We remind you that this manual contains important information on safety and maintenance, and that it must therefore be made accessible to the instrument users. We decline any responsibility deriving from incorrect instrument use that does not comply with this manual.

2. Safety Information



Avoiding Electrical Shock

Before plugging in the power supply, make sure that the supplying voltage of your region matches with the operation voltage of the equipment and that the lamp switch is in off position. Users should observe all safety regulations of the region. The equipment has acquired the CE safety label. However, users have full responsibility to use this equipment safely. Please follow the guidelines below, and read this manual in its entirety to ensure safe operation of the unit.

3. Package content

3.1 B-292/B-292PLI/B-293/B-293PL



- | | |
|----------------------------------|--------------------------------|
| ① Frame | ⑤ Objectives (4X/10X/40X/100X) |
| ② Observation head | ⑥ Dust cover |
| • binocular (B-292/B-292PLI) | ⑦ Power supply |
| • trinocular (B-293/B-293PLI) | ⑧ Immersion oil |
| ③ Photo tube (only B-293 series) | ⑨ Tension adjustment tool |
| ④ Eyepieces | |

3.2 B-292LD1.50/B-292LD1/B-293LD1.50/B-293LD1



- ① Frame
- ② Observation head
 - binocular (B-292LD1/B-292LD1.50)
 - trinocular (B-293LD1/B-293LD1.50)
- ③ Photo tube (only B-293 series)
- ④ Eyepieces
- ⑤ Objectives
 - 10X/20X/40X/50X: B-292LD1.50/B-293LD1.50
 - 10X/20X/40X/100X(dry): B-292LD1/B-293LD1
- ⑥ Dust cover
- ⑦ Fluorescence attachment
- ⑧ Power supply
- ⑨ Tension adjustment tool

3.3 B-290TB



- ① Frame
- ② Digital observation head
- ③ Eyepieces
- ④ Objectives (4X/10X/40X/100X)
- ⑤ Dust cover
- ⑥ Immersion oil

- ⑦ Power supply
- ⑧ Tension adjustment tool
- ⑨ Digital imaging unit power supply
- ⑩ USB cable 0,5 m
- ⑪ Digital imaging unit

NOTE: OPTIKA reserves the right to make corrections, modifications, enhancements, improvements and other changes to its products at any time without notice.

4. Unpacking

The microscope is housed in a moulded Styrofoam container. Remove the tape from the edge of the container and lift the top half of the container. Take some care to avoid that the optical items (objectives and eyepieces) fall out and get damaged. Using both hands (one around the arm and one around the base), lift the microscope from the container and put it on a stable desk.



Do not touch with bare hands optical surfaces such as lenses, filters or glasses. Traces of grease or other residuals may deteriorate the final image quality and corrode the optics surface in a short time.

5. Intended use

Standard models

For research and teaching use only. Not intended for any animal or human therapeutic or diagnostic use.

IVD Models

Also for diagnostic use, aimed at obtaining information on the physiological or pathological situation of the subject.

6. Symbols and conventions

The following chart is an illustrated glossary of the symbols that are used in this manual.



CAUTION

This symbol indicates a potential risk and alerts you to proceed with caution.



ELECTRICAL SHOCK

This symbol indicates a risk of electrical shock.

7. Instrument description

7.1 B-292/B-292PLI/B-293/B-293PL

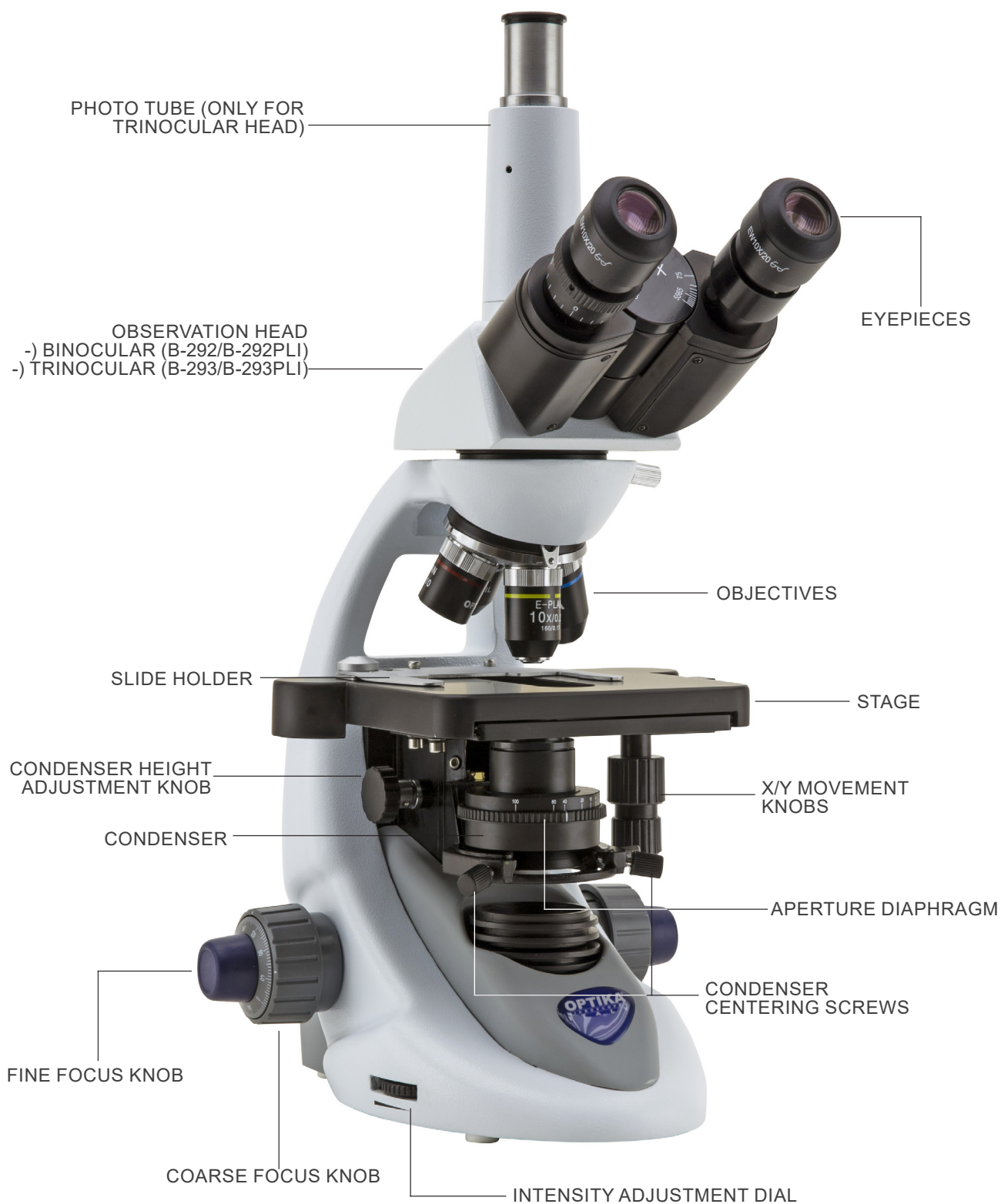

7.2 B-292LD1.50/B-292LD1/B-293LD1.50/B-293LD1

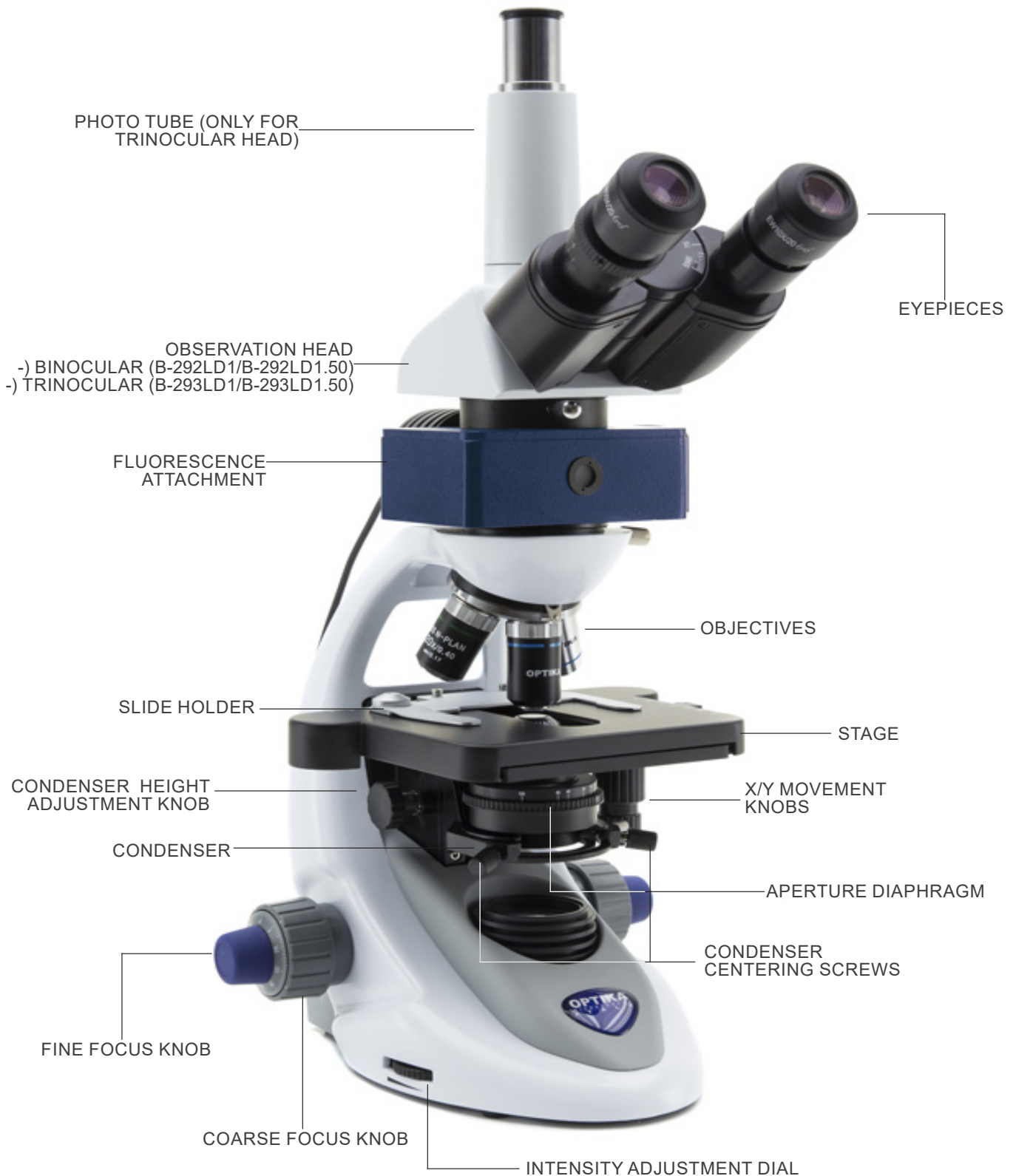

7.3 B-290TB

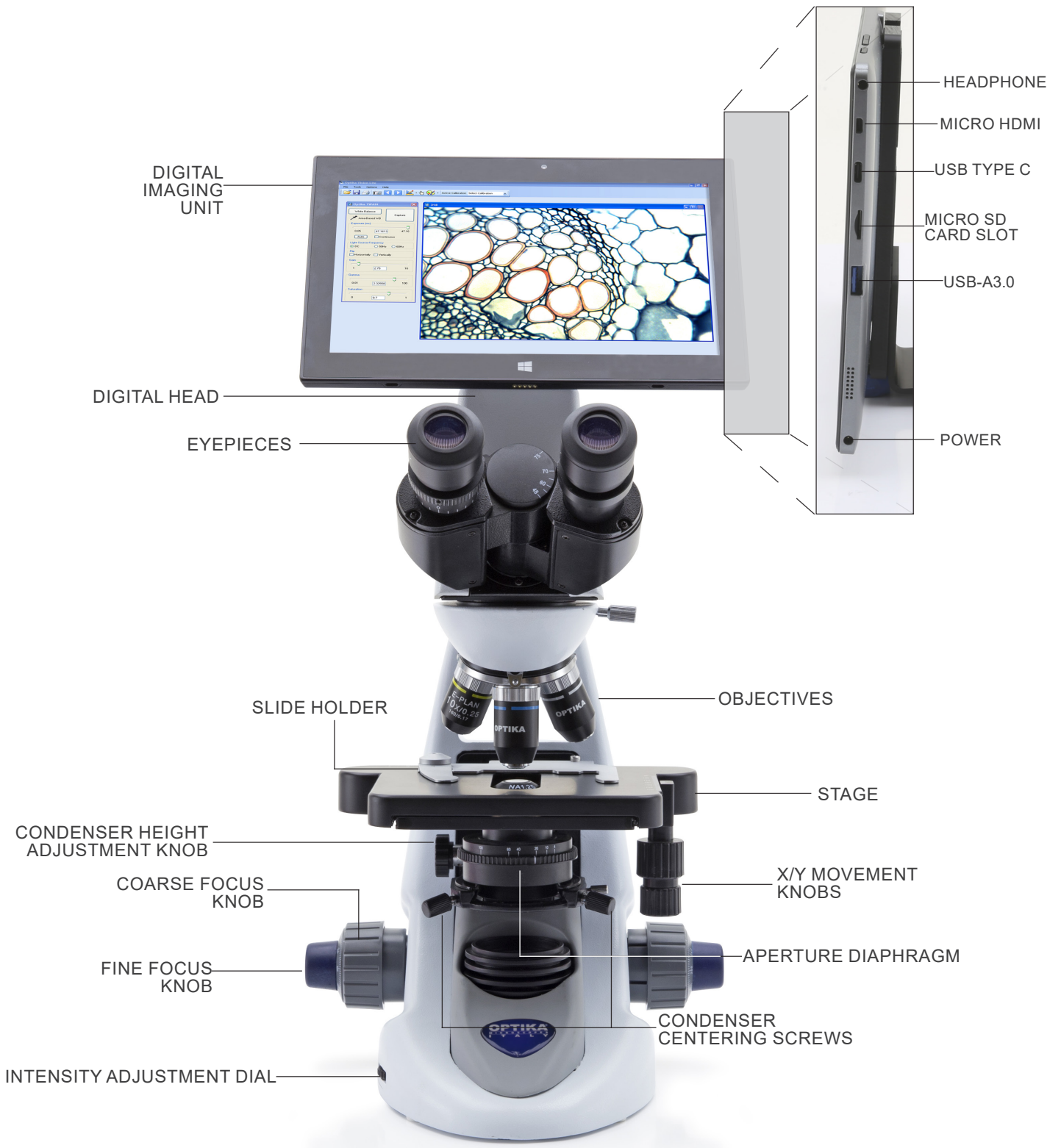

8. Assembling

8.1 Assembling the microscope

8.1.1 B-292/B-292PLI/B-293/B-293PLI

1. Remove the dust cap from the microscope frame and from the bottom of the observation head.
 2. Insert the optical head above the stand and tighten the screw. (Fig. 1)
- **Hold the head with one hand during the locking in order to avoid that the head falls.**



3. Insert both eyepieces into the tubes of the optical head. (Fig. 2)



4. Insert the power supply jack in the socket placed at the rear side of the microscope. (Fig. 3)



Only for trinocular head

5. Unscrew the protection cap mounted on the photo port and screw the photo tube. (Fig. 4)



8.1.2 B-292LD1/B-292LD1.50/B-293LD1/B-2932LD1.50

1. Insert the fluorescence attachment above the frame and tighten the locking screw. (Fig. 5)



2. Insert the cable in the socket placed at the rear side of the microscope. (Fig. 6)



3. Insert the optical head above the stand and tighten the screw. (Fig. 7)
 - **Hold the head with one hand during the locking in order to avoid that the head falls.**



4. Insert both eyepieces into the tubes of the optical head. (Fig. 8)



5. Insert the power supply jack in the socket placed at the rear side of the microscope. (Fig. 9)



Only for trinocular head

6. Unscrew the protection cap mounted on the photo port and screw the photo tube. (Fig. 10)



8.1.3 B-290TB

1. Remove the dust cap from the microscope frame and from the bottom of the observation head.
 2. Insert the optical head above the stand and tighten the screw. (Fig. 11)
- **Hold the head with one hand during the locking in order to avoid that the head falls.**



3. Insert both eyepieces into the tubes of the optical head. (Fig. 12)
4. Insert the power supply jack in the socket placed at the rear side of the microscope. (Fig. 9)



5. Fix the rotating part of the junction using the black wing-nut ①. (Fig. 13)

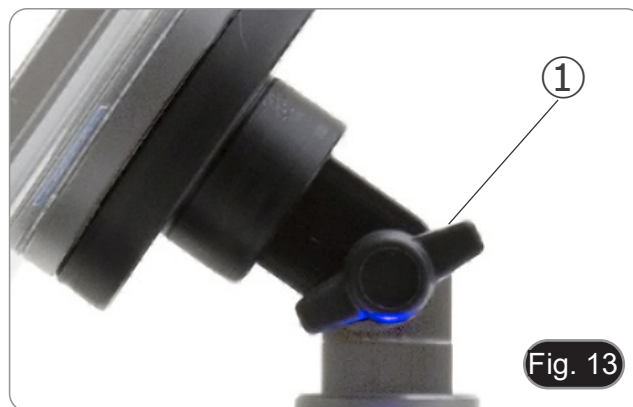

6. Then hook the digital imaging unit onto the 4 screws of the junction and pull toward down to firmly lock the Digital imaging unit in the holder. (Fig. 14)

- To unlock the digital imaging unit proceed with the opposite operation: push toward up and remove it from the holder.



7. Plug one side of the USB cable ② to the digital head and the other side to the digital imaging unit using the connector ③. (Fig. 15-16).

8. Plug the power supply cable to the digital imaging unit for battery recharge using the connector ④. (Fig. 16)

- The digital imaging unit has been set with the Rotation function disabled: this prevents any flipping of the Live View in order to get a continuous and as large as possible view of your slide also when the Digital imaging unit is removed from the holder.
- To enable this function again: you can activate the Rotation by swiping the screen on his bottom right side and selecting Settings + Screen. Anyway, it's not suggested to activate the function when the camera is in Live View mode as it may give troubles when the camera runs at high resolutions.

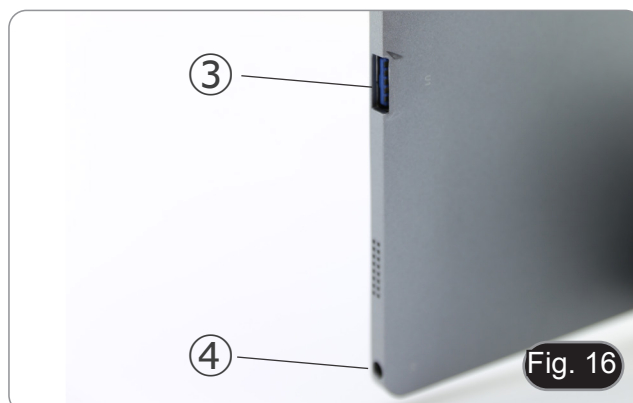

8.2 Polarizing set (optional)

1. Place the polarizer on the light exit ① at the base of the microscope. (Fig. 17)



2. Loosen the head fixing knob ② and remove the head from the microscope frame. (Fig. 18)

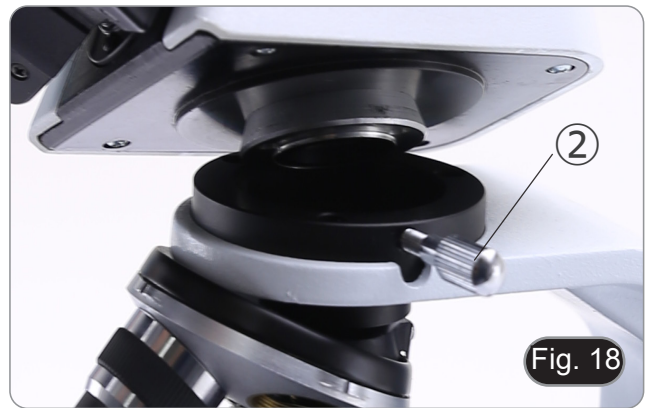

3. Insert the analyzer into the hole inside the frame ③. (Fig. 19)
4. Put back the head into its original position and lock the fixing knob.

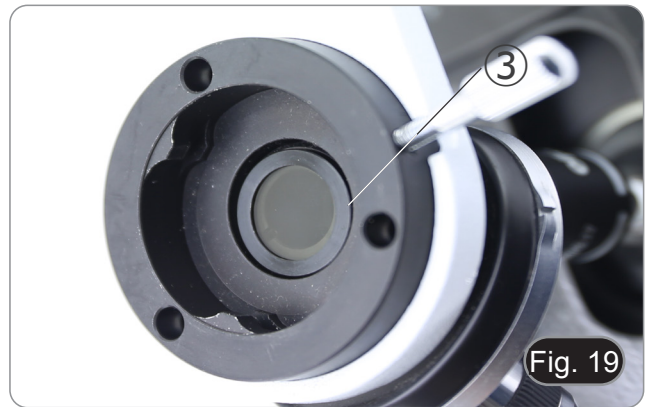

9. Use of the microscope

9.1 Switching on the microscope

1. Operate on the main switch ① placed in the rear side of the microscope, moving the selector on "I" (Fig. 20)
- For "LD" models only: there is a three-position switch on the rear of the stand: position "I" turns on the transmitted light, position "II" turns on the fluorescence and position "O" turns off the microscope.



Fig. 20

9.2 Light intensity adjustment

1. Operate on the light intensity dial to increase or decrease the illumination intensity. (Fig. 21)



Fig. 21

9.3 Coarse focus tension adjustment

- Adjust the tension using the provided tool.

The coarse knob tension is preset in the factory.

1. To modify the tension according to personal's needs, rotate the ring using the provided tool (Fig. 22).
- Clockwise rotation increases the tension.
 - If the tension is too loose, the stage could go lower by itself or the focus easily lost after fine adjustment. In this case, rotate the knob in order to increase the tension.



Fig. 22

9.4 Stage

Stage accepts standard slides 26 x 76 mm, thickness 1,2 mm with coverslide 0,17mm. (Fig. 23)

1. Open the spring arm of the slide holder ② and place the slide from the front on the stage.
 2. Gently release the spring arm of the slide holder.
- **A sudden release of the spring arm could cause the falling of the slide.**

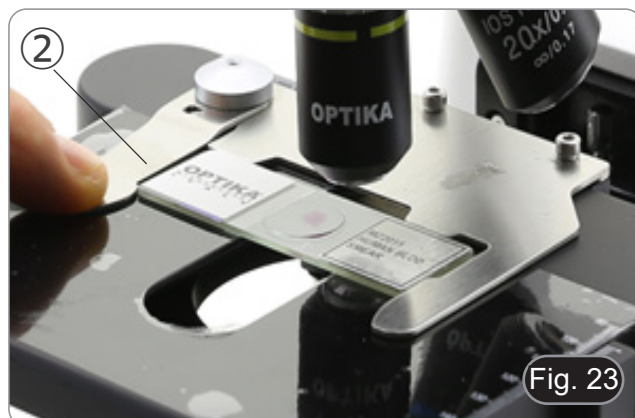

Fig. 23

9.5 Adjust the interpupillary distance

Hold the right and left parts of the observation head using both hands and adjust the interpupillary distance by turning the two parts until one circle of light can be seen. (Fig. 24)

- The graduation on the interpupillary distance indicator ①, pointed by the spot “.” on the eyepiece holder, shows the distance between the operator’s eyes.

The range of the interpupillary distance is 48- 75 mm.

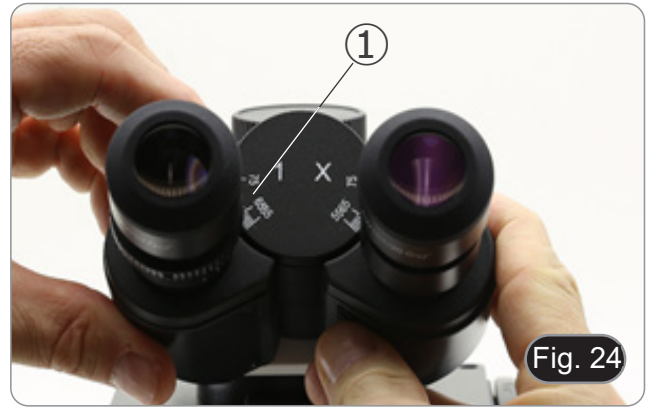

Fig. 24

9.6 Diopter adjustment

1. Look into the right eyepiece with your right eye only, and focus on the specimen.
 2. Look into the left eyepiece with your left eye only. If the image is not sharp, use the diopter adjustment ring ② to compensate. (Fig. 25)
- **The adjustment range is ± 5 diopter. The number indicated on the adjustment ring graduation should correspond to the operator’s diopter correction.**



Fig. 25

9.7 Use of oil immersion objective

All models except LD series

1. Focus the specimen with a low power objective.
 2. Lower the stage.
 3. Put a drop of oil (provided) on the area of the specimen to be observed. (Fig. 26)
- **Make sure that there are no oil bubbles. Air bubbles in the oil damage the image quality.**
 - To check for bubbles: remove an eyepiece, fully open the aperture diaphragm and observe the objective exit pupil. (The pupil must be circular and bright).
 - To remove the bubbles, gently move the nosepiece to the right and left to move the immersion objective a few times and allow the air bubbles to move.
4. Insert immersion objective.
 5. Return the stage to the upper focusing point and obtain an optimal focus using the fine focus knob.
 6. After use, gently remove the oil with a soft paper towel or a slightly moistened optic paper with a mixture of ethyl ether (70%) and absolute ethyl alcohol (30%).
- **The immersion oil, if not immediately cleaned, could crystallize creating a glass-like layer. In this situation the observation of the specimen would be difficult (even not impossible) due to the presence of an additional thickness on the objective.**



Fig. 26

9.8 Condenser centering

- The condenser is installed and pre-centered in the factory.
- To remove the condenser use an Allen wrench 1.5 mm and operate on the fixing knob placed on the right side of the condenser holder.

Should a new centering is needed, operate in this way:

1. Insert 4x objective in the light path (in case 4x is not available use the lower magnification available).
2. Focus the specimen.
3. Close the aperture diaphragm using the ring ①, moving the ring to the value "4" related to the 4x objective. (Fig. 27)
4. Raise the condenser to the upper limit using the height adjustment knob ② placed on the left side of the condenser holder.
5. Center the condenser using the centering screws ③ until the field of view is evenly illuminated (in the field of view no dark and bright areas must be noticed).
6. Fully open the diaphragm.



9.9 Aperture diaphragm

- The Numerical Aperture (N.A.) value of the aperture diaphragm affects the image contrast. Increasing or reducing this value one can vary resolution, contrast and depth of focus of the image. Move the diaphragm ring ① (Fig. 27) on the value corresponding to the objective in use. In this case the optimal setting of the condenser is achieved.
- With low contrast specimens set the numerical aperture to about 70%-80% of the objective's N.A. If necessary, remove on eyepiece and, looking into empty sleeve, adjust the condenser's diaphragm in order to obtain an image like the one in Fig. 28.
- **NOTE: The condenser has an A.N. of 1.25. However, this value is only obtained when the condenser is used "with oil," i.e., by placing a drop of oil on the front lens of the condenser. If the condenser is used "dry," the maximum A.N. that can be obtained is 0.9.**

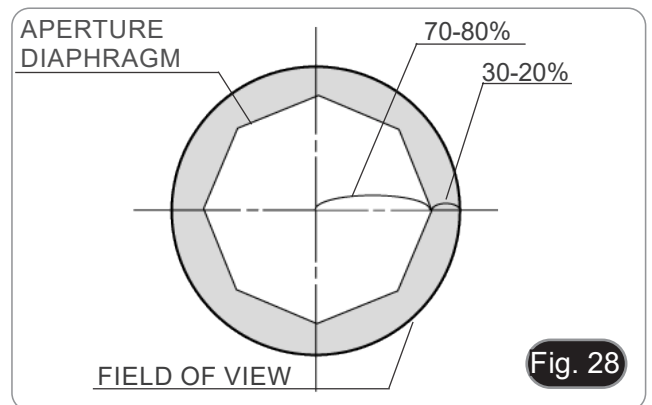

9.10 Use of fluorescence

- Operate on the main switch placed in the rear side of the microscope.
 - Setting on "I" turns on transmitted light, setting on "II" turns on fluorescence. Setting on "O" turns off the microscope. (Fig. 29)
- Move the filter selector in the "B" position (Fig. 30) to insert the fluorescence filter in the light path. Move the selector in the middle to work with brightfield transmitted light.
 - Unlike a mercury lamp system, B-290LD LED illumination doesn't need any power-up time for heating, and can be used immediately after switching on. Also, the LED source is pre-aligned in factory and doesn't need any alignment operation.
- Focus on your sample, and adjust the light intensity as needed through the brightness adjustment knob. In order to improve the darkness of the background (thus improving contrast), it is strongly suggested to put a dark cover on the light exit at the base of the microscope.



Fig. 29



Fig. 30

FILTER NAME	EXCITATION FILTER	DICHROIC MIRROR	EMISSION FILTER	APPLICATIONS
B	460-495 nm	505 nm	510LP nm	<ul style="list-style-type: none"> FITC: fluorescent antibodies Achridine orange DNA/RNA Auramine

9.11 Use of the polarizer (optional)

- Remove the specimen from the stage.
- Looking inside the eyepieces, rotate the polarizer until the darkest position is achieved.
- Once the dark is achieved ("extinction" or "Crossed Nicol" position) it is possible to begin the observation.

9.12 Phase Contrast observation (optional)

Slider phase contrast condenser (Fig. 31) allows observation in brightfield and in phase contrast with 10X/20X/40X objectives.



Observation mode	Slider position
Brightfield	0
Phase contrast 10X/20X	10
Phase contrast 40X	40

9.12.1 Brightfield observation (BF)

1. Move the condenser slider in the central position to insert the empty hole.
2. Center the condenser as described in chapter 9.8 and start working normally.



9.12.2 Phase Contrast observation (PH)

1. Center the condenser as already described in the chapter 9.8.
2. Move the condenser slider all the way toward left to insert the phase ring dedicated to 10X/20X objective. (Fig. 32)
3. Insert 10X or 20X objective into the light path.
4. Open aperture diaphragm.
5. Place a specimen on the stage and focus.
6. Remove one eyepiece and insert the centering telescope. (Fig. 33)

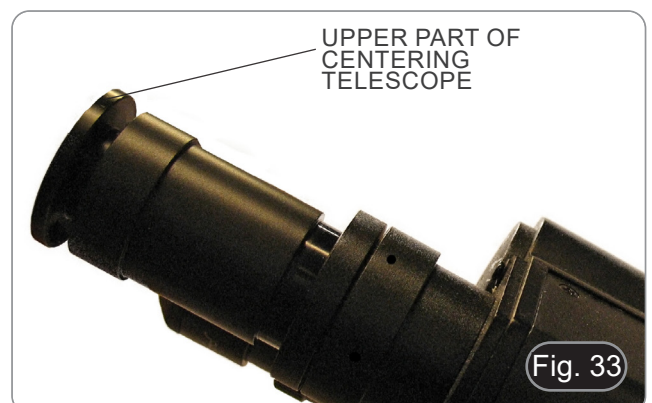

7. Rotate the upper part of the centering telescope (Fig. 33) until the two phase rings (one dark ③ and one bright ②) visible in the telescope are in focus. (Fig. 34)
8. Using centering screws on the slider ④ (Fig. 35), center the phase rings to make the bright ring ② be concentric to the dark ring ③. (Fig. 36)
9. Move the condenser slider all the way toward right to insert the phase ring dedicated to 40X objective.
10. Insert 40X objective into the light path.
11. Repeat steps 7. and 8. to check the centering of the 40x phase ring.
12. At the end, remove the centering telescope, reinstall the eyepiece and begin observation.
 - **With 40x objective it may be useful to slightly raise the condenser, to obtain a better projection of the phase rings. This is not a defect.**
 - **With the 4X objective, the condenser could have a dark halo at the periphery of the field of view. This is not to be considered a defect.**

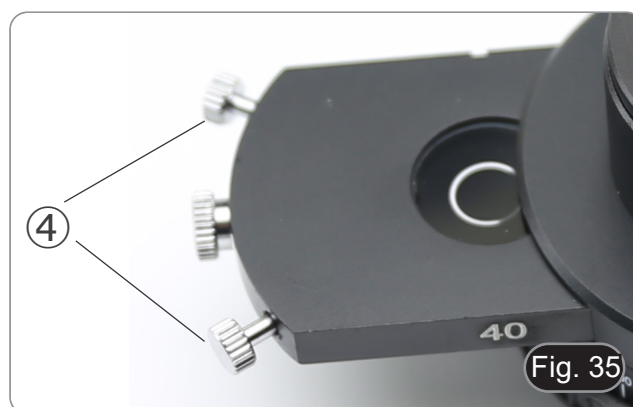
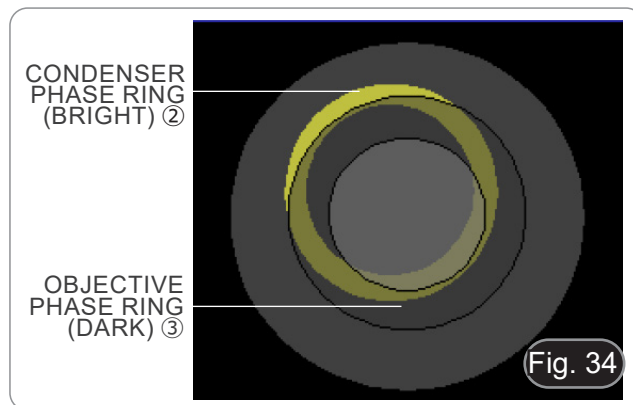

10. Microphotography

10.1 Cameras with projection lens

1. Remove dust caps from camera and projection lens.
2. Screw the projection lens to camera thread. (Fig. 37)

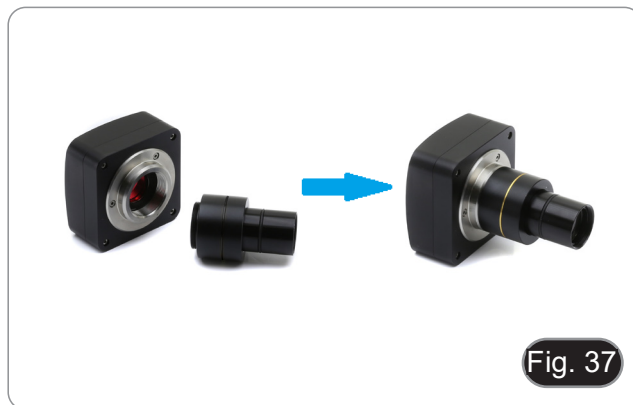

3. Insert the projection lens into the photo tube. (Fig. 38)



10.2 Reflex camera

1. Screw the "T2" ring (not provided) at the end of the projection lens (M-173), then install everything to the reflex camera. (Fig. 39)



2. Insert the projection lens into the photo tube. (Fig. 40)



11. Use of software and digital head

The camera inside the digital head is driven by PROVIEW software.

For the instructions about the use of the software, please refer to the specific instruction manual.

The manual can be accessed by selecting *Help > Help Contents*. A PDF file containing the software instruction manual will open.

12. Micrometric Slide M-005

Micrometric slide, 26x76mm, with 2 scales
(1mm/100div. for biological microscopes / 10mm/100div. for stereomicroscopes)



1 DIV=0.01mm

For biological microscopes calibration



1 DIV=0.1mm

For stereo microscopes calibration

13. Maintenance

Microscopy environment

This microscope is recommended to be used in a clean, dry and shock free environment with a temperature of 5°-40°C and a maximum relative humidity of 85 % (non condensing). Use a dehumidifier if needed.

To think about when and after using the microscope



- The microscope should always be kept vertically when moving it and be careful so that no moving parts, such as the eyepieces, fall out.
- Never mishandle or impose unnecessary force on the microscope.
- Never attempt to service the microscope yourself.
- After use, turn off the light immediately, cover the microscope with the provided dust cover, and keep it in a dry and clean place.

Electrical safety precautions



- Before plugging in the power supply, make sure that the supplying voltage of your region matches with the operation voltage of the equipment and that the lamp switch is in off-position.
- Users should observe all safety regulations of the region.
- The equipment has acquired the CE safety label. However, users do have full responsibility to use this equipment safely.

Cleaning the optics

- If the optical parts need to be cleaned try first to: use compressed air.
- If that is not sufficient: use a soft lint-free piece of cloth with water and a mild detergent.
- And as a final option: use the piece of cloth moistened with a 7:3 mixture of ethanol and ether.
- **Note: ethanol and ether are highly flammable liquids. Do not use them near a heat source, near sparks or near electric equipment. Use these chemicals in a well ventilated room.**
- Remember to never wipe the surface of any optical items with your hands. Fingerprints can damage the optics.
- Do not disassemble objectives or eyepieces in attempt to clean them.

For the best results, use the OPTIKA cleaning kit (see catalogue).

If you need to send the microscope to Optika for maintenance, please use the original packaging.

14. Troubleshooting

Review the information in the table below to troubleshoot operating problems.

PROBLEM	CAUSE	SOLUTION
I. Optical Section:		
LED operates, but field of view remains dark	Power supply is unplugged	Connect
	Brightness is too low	Set brightness to a proper level
	Fluorescence filter is not suitable for the specimen	Use a suitable filter
Dirt or dust is visible in the field of view	Dirt/dust on the specimen	Clean the specimen
	Dirt/dust on the eyepieces	Clean the eyepieces
Image looks double	Aperture diaphragm is stopped down too far	Open aperture diaphragm
Visibility is poor <ul style="list-style-type: none"> • Image is not good • Contrast is poor • Details are indistinct • Image glares 	Revolving nosepiece is in an incorrect position	Move the nosepiece to a click stop
	Aperture diaphragm is too closed or too open	Adjust aperture diaphragm
	Dust or dirt on lenses (condenser, objectives, eyepieces and slide)	Clean thoroughly
	For transmitted light observation, the coverglass thickness must not exceed 0.17mm	Use a coverglass with thickness 0.17mm
	Focus is not even	Slide holder is not flat. Move the specimen to a flat position
One side of the image is out of focus	The nosepiece is not in the center of the light path	Turn the nosepiece to a click stop
	The specimen is out of place (tilted)	Place the specimen flat on the stage
	The optical performance of the sample cover glass is poor	Use a cover glass of better quality
II. Mechanical Section:		
The coarse focus knob is hard to turn	Tension adjustment ring is too tight	Loosen the tension adjustment ring
The focus is unstable	Tension adjustment ring is too loose	Tighten the tension adjustment ring
III. Electric section:		
The LED doesn't turn on	No power supply	Check the power cord connection
The brightness is not enough	The brightness adjustment is low	Adjust the brightness
The light blinks	The power cord is poorly connected	Check the power cord
IV. Observation tube:		
Field of view of one eye does not match one to each other	Interpupillary distance is incorrect	Adjust interpupillary distance
	Incorrect diopter adjustment	Adjust diopter
	Your view is not accustomed to microscope observation	Upon looking into eyepieces, try looking at overall field before concentrating on specimen range. You may also find it helpful to look up and into distance for a moment before looking back into microscope
V. Microphotography:		
Image edge is unfocused	To a certain extent it is due to achromatic objectives features	To minimize the problem, set the aperture diaphragm in a proper position
Bright spots appear on the image	Stray light entering in the microscope through eyepieces or camera viewfinder	Cover eyepieces and viewfinder with a dark cloth

Equipment disposal

Art.13 Dlsg 25 July 2005 N°151. “According to directives 2002/95/EC, 2002/96/EC and 2003/108/EC relating to the reduction in the use of hazardous substances in electrical and electronic equipment and waste disposal.”



The basket symbol on equipment or on its box indicates that the product at the end of its useful life should be collected separately from other waste. The separate collection of this equipment at the end of its lifetime is organized and managed by the producer. The user will have to contact the manufacturer and follow the rules that he adopted for end-of-life equipment collection. The collection of the equipment for recycling, treatment and environmentally compatible disposal, helps to prevent possible adverse effects on the environment and health and promotes reuse and/or recycling of materials of the equipment. Improper disposal of the product involves the application of administrative penalties as provided by the laws in force.

OPTIKA® S.r.l.

Via Rigla, 30 - 24010 Ponteranica (BG) - ITALY Tel.: +39 035.571.392
info@optikamicroscopes.com - www.optikamicroscopes.com

OPTIKA® Spain

spain@optikamicroscopes.com

OPTIKA® USA

usa@optikamicroscopes.com

OPTIKA® China

china@optikamicroscopes.com

OPTIKA® India

india@optikamicroscopes.com

OPTIKA® Central America

america@optikamicroscopes.com
